

VACALL™

All Excavate 811



All Excavate
811

SPECIFICATIONS

GENERAL SPECIFICATIONS

Drive: Split shaft PTO with direct drive to blower
Silencer: Outlet silencer based on blower requirements
Electrical: 12 volt CAN bus system with sealed connectors

VACUUM SYSTEM

Blower: Howden-Roots 8x24 with two vacuum reliefs
Vacuum: 3,500 CFM @ 18" Hg (245"H2O)
185 HP @ 2,250 rpm
Blower Airflow: 4,700 CFM free air
Drive: OMSI air shift transfer case, power frame-mounted, step-up ratio
Blower Inlet: Filter housing with 304 SS screen assembly
Cyclone Separator: Single with drop box clean out
Vacuum Relief: Air operated 4" valve controlled at control panel and handheld pendant

WATER SYSTEM

Pump Type: Hydraulically powered triplex plunger
Filter: In-line suction strainer on pump inlet
Water Pump: 0-25 gpm @ 3,000 psi
(94.6 LPM @ 206.8 BAR)
Excavating Hose Reel: Hannay spring rewind, 0.5" x 75' capacity, includes 75' of 0.5" high pressure, high temperature hose
Standard Handgun, Lance, and Nozzle Kit: (1) Handgun/lance assembly, (2) extension lances with quick couplers and 1-3 place wedge digging nozzle, 50' handgun hose with quick couplers on each end, 3,000 psi hose shipped loose
Drain Valves: High pressure section, water pump suction line, strainer on water pump inlet, cut-off on water pump inlet line
Water Pressure Relief Valve: Adjustable
Air Purge System
Cold Weather Recirculation: Using Main Water Pump

DEBRIS TANK

Volumetric Capacity: 8 cubic yards
Dump Angle: 42°
Construction: Oval shape, cylindrical sides, wrap-around gussets plus rear mount boom
Sides: .250" thick steel
Lifting: Hydraulic 3-stage telescopic cylinder
Debris Body Safety Prop: Single prop manually operated, located on hoist frame near rear axles
Tailgate: Heavy-duty rear 90° hydraulically opening with dual positive hydraulic locks with reverse-angle wedges
Tailgate Safety Prop: Located outside beside tailgate driver side
Carbon Steel Float Ball Cage
Stainless Steel Float Ball Shut-Off
Carbon Steel Splash Shield
Float Level Indicator
Interior and Exterior Powder Coated
6" Decant Port on Rear Door: 6" brass slide gate valve, 6" Lay Flat Hose, Storage Basket
Sludge Pump Port

BOOM HOSE

Hose: 8" bore x 330" long, single piece rubber hose, boom turret head to end connector
Hose Construction: Smooth bore NR/SBR liner
Hydraulic Boom: Rear mounted
Boom Rotation: 327°

HYDRAULIC SYSTEM

Hydraulic Pump: Pressure-compensated piston pump with ORS fittings
Hydraulic Reservoir: 51 gal max
Return Filter: 5 microns

OPERATOR CONTROLS

AllSmartFlow Control Panel: Enclosed cabinet control box containing: CAN bus boom control joystick recessed for protection. LCD color display with 32 output microprocessor control (expandable), J1939 can communication, increase/decrease engine RPM, tachometer, hour meter, water pressure psi, vacuum Hg, water pump hour meter, blower hour meter, vacuum gauge, low water light
Boom Control Joystick: Recessed for protection
Throttle Control: Increase and decrease RPM
Water Pump: On, off, increase and decrease pressure
Blower: On, off, increase and decrease vacuum
Vacuum Relief: Open and close
Electric Implement Controls: Debris tank raise and lower, rear door open and close, vibrator, and sludge pump
Emergency Stop
Electrical Controls and Wiring Harness: Ip66 sealed exterior, protective cover exceeds Nema 4 rating
Transfer Case Shift Controls
Two Channel Camera System: 7" Swivel Color LCD Monitor (Back Up)

POWER MODULE

Vacuum Pump: Direct drive
Hydraulic Level Sight Gauge
Hydraulic Reservoir Shut-Off Valve(s)
Platform and Steps-On Power Frame
Hydraulic Pump: Single Independent Implement System
Transfer Case: Remote sight glass and fill
Standard Shelf
Tube Storage at Power Module

WATER TANKS

Volumetric Capacity: 1,100 gallons
Construction: High-quality fully welded aluminum
Water Tank Fill: 4" air gap with water tank electronic level indicator on control panel display
2-1/2" Y-Strainer on Fill Line
Sight Level Tube on Passenger Side Water Tank

VACALL™



SPECIFICATIONS (cont.)

CHASSIS

Electric Back Up Alarm
 Factory Mounted Tandem Axle, Fenders
 Mud Flaps Behind Rear Tires
 Rear Dot Under Ride Protection (Bumper)

LIGHTING

LED D.O.T. Lighting: Stop, tail, turn and back-up
 LED Boom Work Lights

PACKAGED ITEMS

1/2" Blue Star Raven Nozzle
 8" Vacuum Tubes: Flat flanged style aluminum tubes: 5' (x2), 4' (x2), 3' (x1)
 6" Vacuum Tube: Flat flanged style aluminum tube with rubber hydro-x end: 7' (x1)
 Tube Clamps: 8" (x6), 6" (x1)
 Gaskets: 8" (x6)
 Reducer: 8" X 6" (x1)
 Pendant Remote Control: 50' long with throttle control, boom functions and vacuum relief valve controls

PACKAGED ITEMS (CONT.)

Fill Hose: 25' X 2 1/2"
 Hydrant Wrench
 Emergency Road Kit
 Fire Extinguisher (5#)

PAINT

Powder Coat: Subframe, power frame, exhaust silencer, debris tank exterior and interior, air/water separator exterior only

VACALL ALLEXCAVATE 811 CHASSIS REQUIREMENTS

Vehicle configuration

- Set forward axle - truck

General service

- Expected front axle(s) load: 20,000 lb (max weight)
- Expected rear drive axle(s) load: 46,000 lb (max weight)
- Expected gross vehicle weight capacity: 66,000.0 lb (max weight)
- Domiciled, USA 50 states (including California and carb opt-in states)

Engine

- Cummins L9 370 hp @ 2100 rpm, 2100 gov rpm, 1250 lb-ft @ 1200 rpm

Engine equipment

- 2010 EPA/CARB/GHG21 configuration (dependent on registration state)
- 2008 CARB emission certification - clean idle (includes 6" x 4" label on left side of hood)
- 12 volt, 160 amp alternator
- Passenger side outboard under step mounted horizontal after-treatment system assembly with passenger side b-pillar mounted vertical tailpipe
- 13 gal diesel exhaust fluid tank (mounted under cab)

Transmission

- Allison 3000 RDS automatic transmission with side/side PTO provision (minimum)

Transmission equipment

- PTO mounting, driver side and passenger side of main transmission

Rear suspension

- Hendrickson RT463 @ 46,000 lb rear suspension
- 54" axle spacing

Brake system

- Air dryer reservoir mounted (no sideout frame mount)

Wheelbase & frame

- Frame overhang: 65"+ (1.65 m)
- Calculated effective back of cab to rear suspension c/l (ca): 195.03" (Usable ca 195" minimum)

Chassis equipment

- Clear frame rails 36" from back of cab inside/outboard/below both frame rails

Fuel tanks

- 100 gal / 25" diameter fuel tank(s)

VEHICLE SPECIFICATIONS SUMMARY – FRAME RBM

Wheelbase (545).....	282" (7,150 mm)
Frame Rails (546)	0.5" x 3.64" x 11.875" (12.7 mm x 92.5 mm x 301.6 mm) steel
120KSI (546)	
Yield Strength (psi).....	120,000
Section Modulus (per rail) (cu in).....	26.26
RBM (per rail) (lbf-in)	3,204,000
Inner Frame Reinforcement (547)	0.25" (6.35 mm) c-channel inner frame reinforcement
RBM (per rail) (lbf-in)	1,205,000
Outer Frame Reinforcement (548)	No outer frame reinforcement

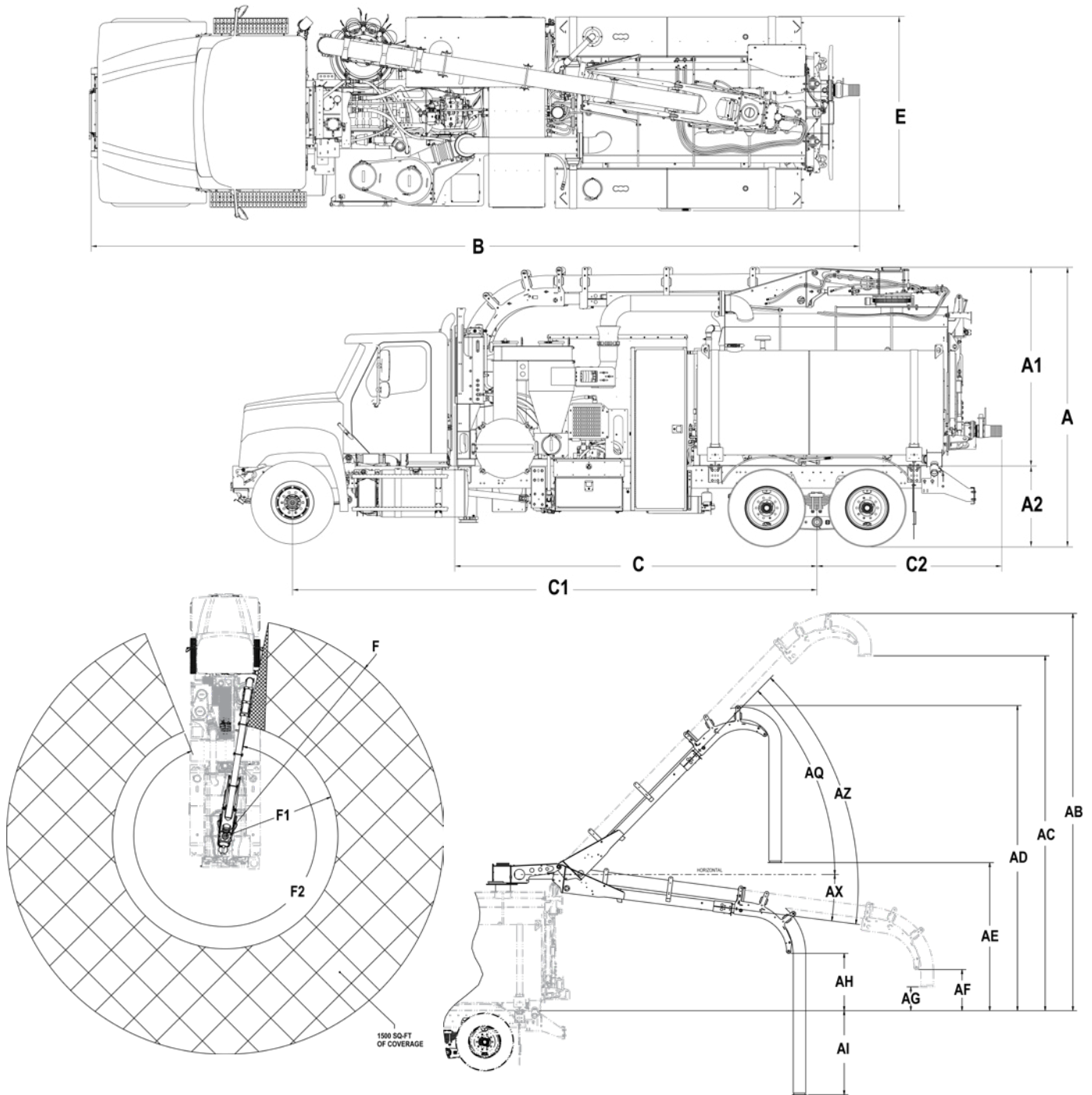

DIMENSIONS

A	~12'6" (3.8m)	Overall Stored Height	AB	~23'10" (7.26m)	Boom Max Working Height Extended
A1	~8'11" (2.7m)	Module Stored Height	AC	~21'4" (6.5m)	Hose Max Height Extended
A2	CHASSIS VARIABLE	Chassis Frame Height	AD	~18'4" (5.58m)	Boom Working Height Retracted
B	~34'5" (10.49m)	Overall Length	AE	~8'11" (2.71m)	Hose Height Retracted
C	~16'3" (4.93m)	Module Length Front	AF	~2'6" (0.76m)	Boom Min Height Extended
C1	~23'6" (7.16m)	Wheelbase	AG	~1'5" (0.43m)	Hose Min Height Extended
C2	~8'3" (2.5m)	Module Length Rear	AH	~3'5" (1.04m)	Boom Min Height Retracted
E	~8'8¼" (2.64m)	Overall Width	AI	~5'1" (1.54m)	Hose Min Height Retracted
F	~26'8" (8.12m)	Boom Max Reach	AQ	46°	Boom Max Up Angle
F1	~13'9" (4.19m)	Boom Min Reach	AZ	53°	Boom Total Angle
F2	237°	Boom Rotation	AX	7°	Boom Mad Down Angle

NOTE: All dimensions shown are applicable to Freightliner M2-106 Chassis only.
 * Rear Tandem Axle Required.

OPTIONS

Belly Pack Wireless Pendant: Controls all boom functions, engine RPM, vacuum relief, emergency stop, and water pump speed. Other Functions Also Available.

Air Excavation: Air compressor, low pressure mode up to 110 psi at 185 CFM, high pressure mode up to 150 psi at 150 CFM, spring rewind air hose reel with 75' of 1" hose.

Handheld Wireless Remote

Sludge Pump

4" Brass Slide Gate Valve for Decant

Full Load Indicator

Electric Debris Body Vibrator

Anti-Siphon Fill

Work Lights

Strobe Lights

Toolboxes

Vacuum Tube Racks

Supreme Finished Galvanized Debris Body

Supreme Finished Galvanized Air Water Separator

Supreme Finished Galvanized Tailgate

Camlock Fill Adapter

SS Float Ball Cage

Blaster Valve

SS Hinged Decant Screens

Standpipes - Various sizes

Anti-Splash Valve

Air Compressor

Anti-Freeze Injection

Dual Reels

Hydraulic Rewind Reel

2" Drain Valve on Air Water Separator

2" Drain Valve on Silencer

6" Air Operated Vacuum Relief

Tube in Tube Boom Hose, Steel Elbow or Rubber Elbow

Lube Chart

Blower Temp Gauge

Blower Temp Gauge Connection to Vac Relief

Can/USB Cable

Debris Tank High Level Alarms and Light

Debris Tank High Level Alarms and Light Hooked to Vac Relief

Camera System

Power Pack with Emergency Hydraulics

Remote Emergency Stop

Tool Circuit

Low Water Light and Alarm

Override for Alarms

Spotlights

First Aid Kit

Nozzles

Handguns Pistol and Straight Grip

Vacuum Tubes Various Sizes and Connection Ends



COLD WEATHER PACKAGE OPTION

Boiler: Diesel fired 470,000 Btu

Insulated Aluminum Cabinets

Cabinet Heater

External Waterlines: Insulated with heat trace

Optional Boilers:

- 705,000 BTU Boiler
- 940,000 BTU Boiler

Printed in U.S.A. • Form No. 12302 12/25

Vacall machines are designed and manufactured by Gradall Industries LLC., a world leader in the production of versatile, reliable maintenance machines. It is our policy to continually improve our products. Therefore, designs, materials and specifications are subject to change without notice and without incurring any liability on units already sold. NOTE: some options shown in pictures.

VACALL™

Gradall Industries LLC. • 406 Mill Ave SW • New Philadelphia, OH 44663
Phone: (800) 382-8302
www.vacall.com

