



OPERATING
PERFORMANCE
& EFFICIENCY...



VACALLTM

AllJetVac

COMBO SEWER CLEANER

SETTING NEW VALUE & PERFORMANCE STANDARDS IN SEWER LINE MAINTENANCE

The Best Combination Sewer Cleaner on The Market

AllJetVac combination sewer cleaners provide contractors and governments with excellent jetting action and superior vacuum power to efficiently open clogged sewer lines and perform needed maintenance.



» GALVANIZED DEBRIS BODY

Optional supreme finish that carries a lifetime warranty.

» SINGLE ENGINE

Reduces fuel consumption, emissions, noise, and maintenance.

» SUPERIOR PERFORMANCE

High-efficiency jetting action and vacuum power to clear and maintain sewer lines.

» VERSATILE MODELS

P-Series (front hose reel), R-Series (rear hose reel), and Recycler (continuous water recycling).

» CUSTOMIZABLE OPTIONS

Various power modules, hose reel positions, and debris/water tank capacities.



6 Cubic yard Single Axle

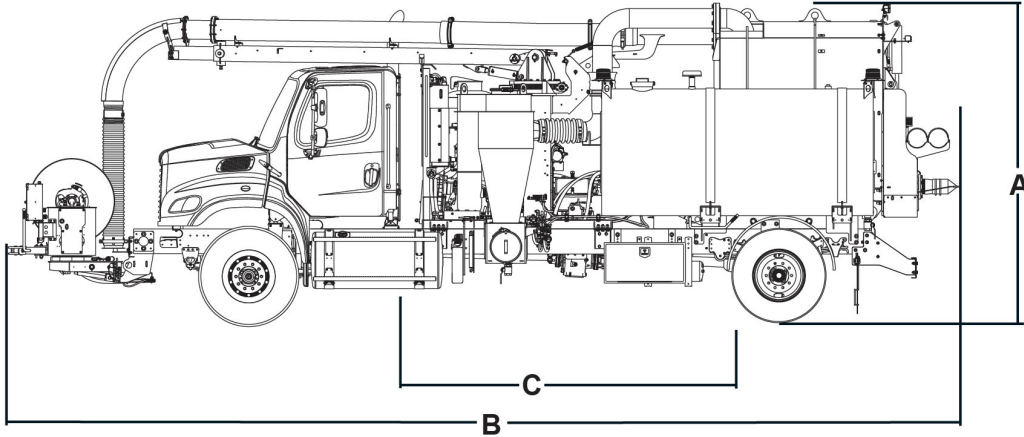

8, 10 or 12 Cubic Yard Tandem Axle

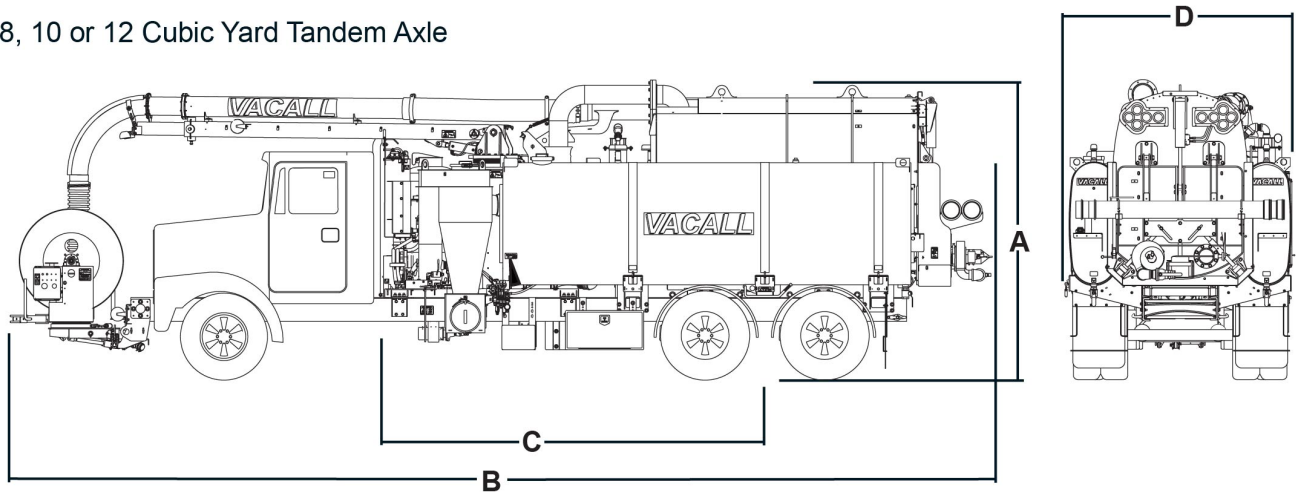

DIMENSIONS	MACHINE MODEL NUMBERS			
	AJV610	AJV810	AJV1015	AJV1215
A. Overall Height	12'0"	12'0"	12'0"	12'0"
B. Overall Length	35'6"	35'6"	37'9"	38'9"
C. Clear CA Required	167"	167"	184.5"	198.5"
D. Overall Width	8'8"	8'8"	8'8"	8'8"

Vacall machines are designed and manufactured by Gradall Industries LLC, a world leader in the production of versatile, reliable maintenance machines. It is their policy to continually improve their products. Therefore, designs, materials and specifications are subject to change without notice and without incurring any liability on units already sold. NOTE: some options shown in pictures.